

Collect and haul bulky, light-density loads

- Rugged, all-metal construction with fully welded, leakproof seams. Tough enough for use in the factory.
- Reinforced dumping knees for complete, controllable manual emptying at floor or dock level.
- Maneuvers easily and rolls smoothly, even when fully loaded.
- Smart design maximizes cube capacity while minimizing footprint thereby preserving valuable floor space.
- Proudly designed and manufactured in the U.S.A.

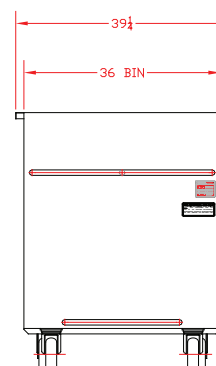

Specification:	340 Series
Capacity:	40 cubic feet
Load Rating:	800 lbs.
Bin Dimensions:	59 1/2" long x 36" wide x 39 1/2" deep
Lip Height:	47 1/4"
Dumping Method:	Tilt / manual
Color:	Black standard, gray optional
Wheels:	6-inch poly*
Add'l Options:	Drain plug Hinged drain cover Tow link Steel cover Cardholder
Shipping Weight:	270 lbs.

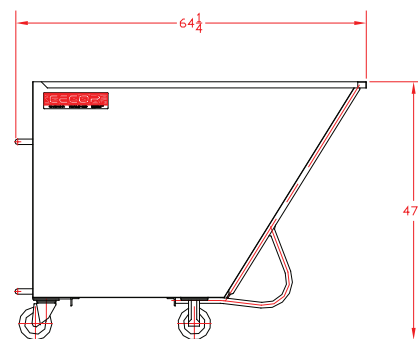

*Other sizes and styles available.