

CECOR®

OPERATION MANUAL & PARTS LIST

MODEL: SA5-60PL



TABLE OF CONTENTS

SECTION 1 – SAFETY INFORMATION	3
1.1 – CAUTION.....	3
1.2 – PRECAUTIONS	4
SECTION 2 – THE SUMP CLEANER.....	5
2.1 – UNIT IDENTIFICATION	5
2.2 – MODEL & SERIAL NUMBER.....	6
2.3 – SUMP CLEANER FEATURES.....	7
SECTION 3 – INSTALLATION.....	9
3.1 – LOOSE ITEMS.....	9
3.2 – INITIAL STARTUP	10
SECTION 4 – OPERATION	14
4.1 – CLEANING A SUMP	14
4.2 – DISCHARGING FLUID FROM THE SUMP CLEANER.....	15
4.3 – FILTER.....	15
4.4 – CLEANING THE SUMP CLEANER	16
SECTION 5 – MAINTENANCE	17
5.1 – DAILY MAINTENANCE.....	17
5.2 – WEEKLY MAINTENANCE	17
5.3 – MONTHLY MAINTENANCE	18
5.4 – SEMI ANNUAL.....	18
SECTION 6 – TROUBLESHOOTING	19
SECTION 7 – REPAIR PARTS LIST.....	20
7.1 – WHEELS & CASTER.....	20
7.2 – TANK & PUMP.....	21
7.3 – FILTER, TOOLS & HOSE	22
7.4 – TANK CONNECTIONS, GAUGE, MOTOR & CONTROL SYSTEMS.....	23
SECTION 8 – WARRANTY	26
SECTION 9 – RECORD MODEL & SERIAL NUMBER.....	27

SECTION 1 – SAFETY INFORMATION

1.1 – CAUTION

 FLAMMABLE INFLAMMABLE	 CAUTION
	THIS EQUIPMENT IS INTENDED FOR USE WITH STANDARD METALWORKING FLUIDS (WATER-BASE & CUTTING OILS) ONLY. IT SHOULD NOT BE USED WITH FLAMMABLE FLUIDS, (FUELS, PAINT, SOLVENTS, ETC.) CORROSIVE, TOXIC OR REACTIVE MATERIALS. DO NOT USE IN EXTRA-HIGH TEMPERATURE OR SPARK-HAZARD ENVIRONMENTS (OVENS WELDING AREAS, ETC.). CLEAN TANK THOROUGHLY ON A FREQUENT BASIS, ESPECIALLY WHEN PUMPING DIFFERENT TYPES OF COOLANTS AND SOLIDS OF DIFFERENT MATERIAL. WE RECOMMEND SEPARATE TANK UNITS FOR DIFFERENT SERVICES AND SEGREGATED HANDLING OF DIFFERENT COOLANTS.
	 CUIDADO
	ESTE EQUIPO ES PARA USO CON FLUIDOS REGULARES DE CORTE (BASE AGUA Y ACEITES DE CORTS) EXCLUSIVAMENTE. NO SE DEBE USAR CON LÍQUIDOS INFLAMABLES, (COMBUSTIBLES, PINTURA, DISOLVENTES, ETC.), MATERIALES CORROSIVOS, TÓXICOS O REACTIVOS. NO UTILIZAR EN AMBIENTES DE TEMPERATURAS ALTAS O DONDE HAY RIESGO DE CHISPAS PELIGROSAS (HORNO, AREAS DE SOLDADURA, ECT.). LIMPIA A FONDO EL TANQUE DE MANERA FRECUENTE, ESPECIALMENTE CUANDO BOMBEE TIPOS DIFERENTES DE FLUIDO DE CORTE Y SÓLIDOS DE MATERIAL DISTINTO . RECOMENDAMOS UNIDADES SEPARADO DE DEPÓSITO DE LOS DIFERENTES SERVICIOS Y SEPARADO EL MANEJO DE DIFERENTES FLUIDO DE CORTE.
 TOXIC TÓXICO	
 CORROSIVE CORROSIVO	
 REACTIVE REACTIVIDAD	

THIS EQUIPMENT IS INTENDED FOR USE WITH STANDARD MACHINE-TOOL COOLANT (WATER-BASE AND CUTTING OILS) ONLY. IT SHOULD NOT BE USED WITH FLAMMABLE FLUIDS (I.E. FUELS, PAINT, SOLVENTS, ETC.), CORROSIVE, TOXIC OR REACTIVE MATERIALS. DO NOT USE IN EXTRA-HIGH TEMPERATURE OR SPARK-HAZARD ENVIRONMENTS (I.E. OVENS WELDING AREAS, ETC.). CLEAN TANK THOROUGHLY ON A FREQUENT BASIS, ESPECIALLY WHEN PUMPING DIFFERENT TYPES OF COOLANT AND SOLIDS OF DIFFERENT MATERIAL. WE RECOMMEND SEPARATE TANK UNITS FOR DIFFERENT SERVICES AND SEGREGATED HANDLING OF DIFFERENT COOLANTS.

- NO FLAMMABLE FLUIDS/MATERIALS WITH A FLASH POINT UNDER 200°F.
- NO TOXIC MATERIALS.
- NO CORROSIVE MATERIALS WITH PH LESS THAN 5 OR GREATER THAN 12.
- NO REACTIVE MATERIALS.

1.2 – PRECAUTIONS

- ❑ READ THROUGH THE "OPERATIONS MANUAL" COMPLETELY BEFORE ATTEMPTING TO OPERATE THE MACHINE.
- ❑ CLEANOUT, POT LID, BLEED-OFF CAP AND HOSES MUST BE TIGHTLY SECURED BEFORE OPERATION IN THE DISCHARGE MODE.
- ❑ TANK DISCHARGE PRESSURE MUST NOT EXCEED 10 PSI. REGULATOR AND RELIEF VALVES ARE SET BEFORE SHIPMENT AND SHOULD NOT BE CHANGED AS THE USE OF EXCESSIVE PRESSURE COULD CAUSE SERIOUS INJURY OR DAMAGE. OPERATING DISCHARGE PRESSURE IS 6 PSI.
- ❑ DO NOT ATTEMPT TO OPEN POT LID, CLEANOUT OR BLEED-OFF CAP BEFORE RELIEVING PRESSURE IN THE TANK.
- ❑ BLOCK WHEELS OF THE MACHINE TO PREVENT UNINTENTIONAL MOVEMENT.
- ❑ WEAR SAFETY GOGGLES TO PROTECT EYES FROM SPLASHING LIQUIDS.
- ❑ KEEP HANDS AND FINGERS CLEAR OF POT OPENING WHEN REMOVING OR REPLACING FILTER BASKET OR FILTER ASSEMBLY.
- ❑ AIR SUPPLY MUST NOT EXCEED 200 PSI

SECTION 2 – THE SUMP CLEANER

2.1 – UNIT IDENTIFICATION

WHEN ORDERING PARTS OR ASKING QUESTIONS REGARDING YOUR SUMP SHARK, IT IS IMPORTANT TO HAVE THE MODEL NUMBER. THE MODEL NUMBER IDENTIFIES YOUR SHARK AND INDICATES STANDARD FEATURES ON YOUR MACHINE. YOU WILL FIND THE MODEL NUMBER ON THE SHARK'S NAMEPLATE LOCATED ON THE BACK PANEL OF THE PUMP BASE.

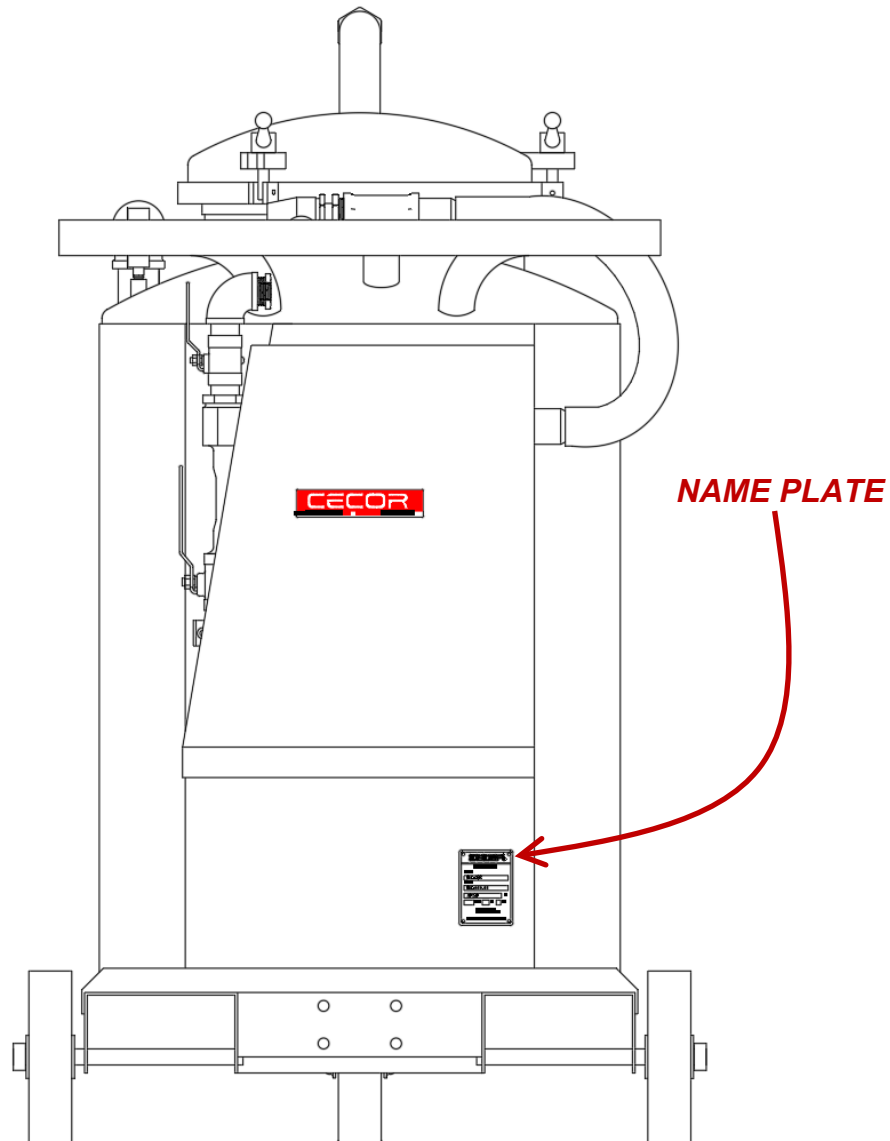

2.2 – MODEL & SERIAL NUMBER

THE MODEL NUMBER IDENTIFIES YOUR SHARK AND INDICATES STANDARD FEATURES ON YOUR MACHINE. THE SERIAL NUMBER IDENTIFIES YOUR SPECIFIC SHARK AND WILL HELP IDENTIFY ANY SPECIAL FEATURES THAT MAY BE UNIQUE TO YOUR SUMP SHARK. THE SERIAL NUMBER IS LOCATED ON THE NAMEPLATE.

CECOR.

CECOR filter cartridges bear
US patent number 4,397,745

MODEL
SA5-60PL

SERIAL
SA5-###-##

70-120 **PSI**

VOLT **HZ** **PH**

1000 James Ave.
Belleville, WI 53508

608-845-6771 www.cecort.net

2.3 – SUMP CLEANER FEATURES

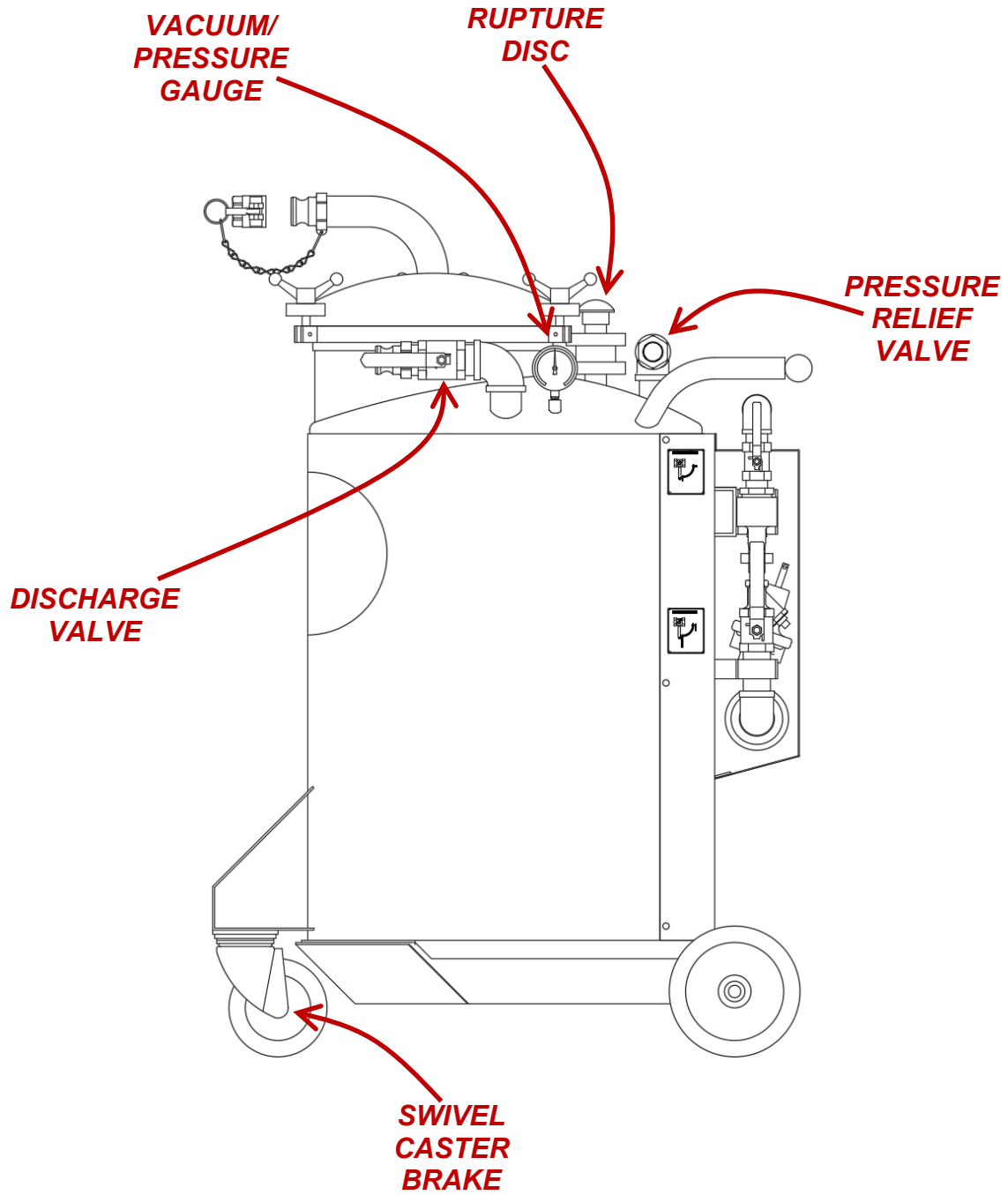

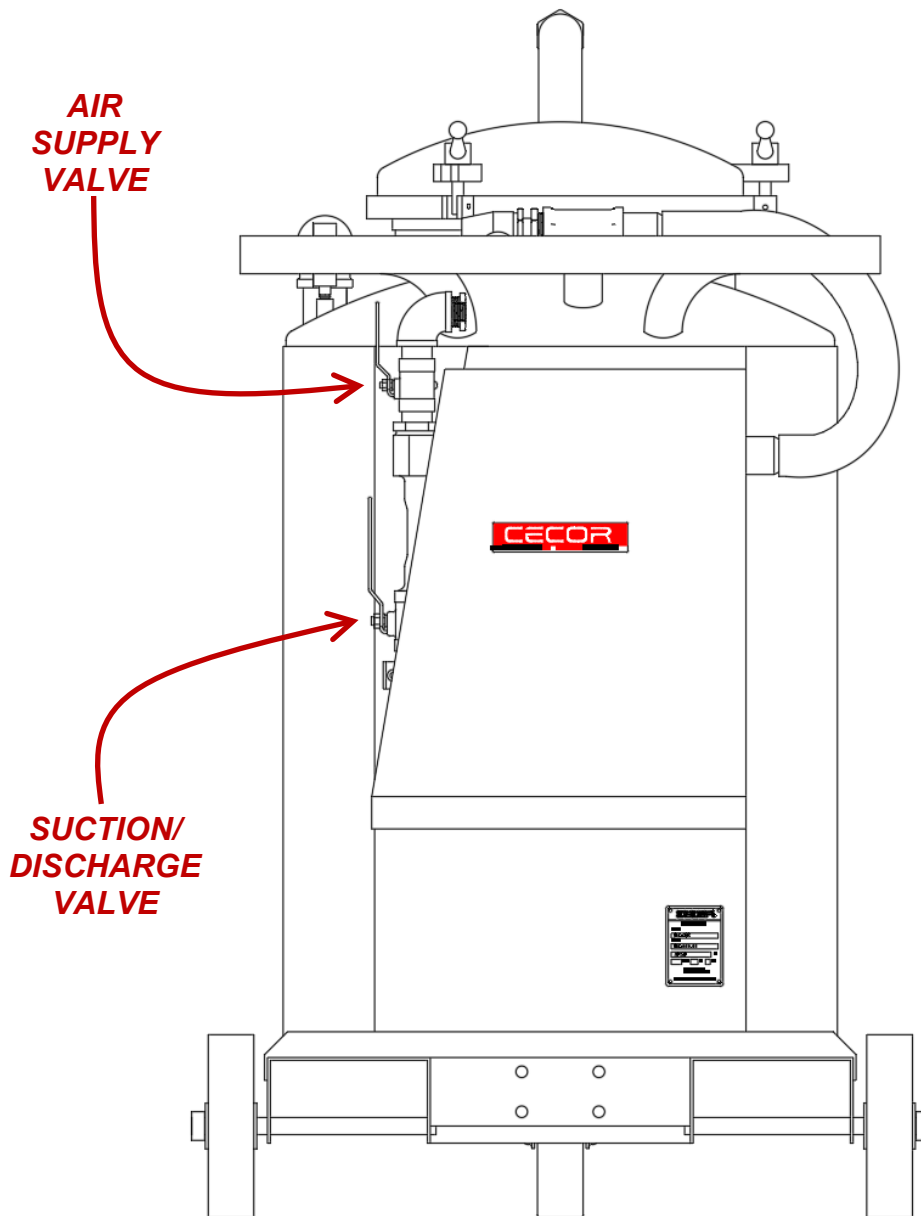

SECTION 3 – INSTALLATION

3.1 – LOOSE ITEMS

SOME ITEMS MAY BE PACKAGED IN A BOX LOCATED ON THE SHIPPING PALLET. PACKAGES WITH FILTER BASKET OR FILTER ASSEMBLIES WILL HAVE FILTERS INSTALLED. PLEASE REVIEW YOUR PACKING LIST TO SEE WHAT ADDITIONAL ITEMS YOU WILL BE RECEIVING.

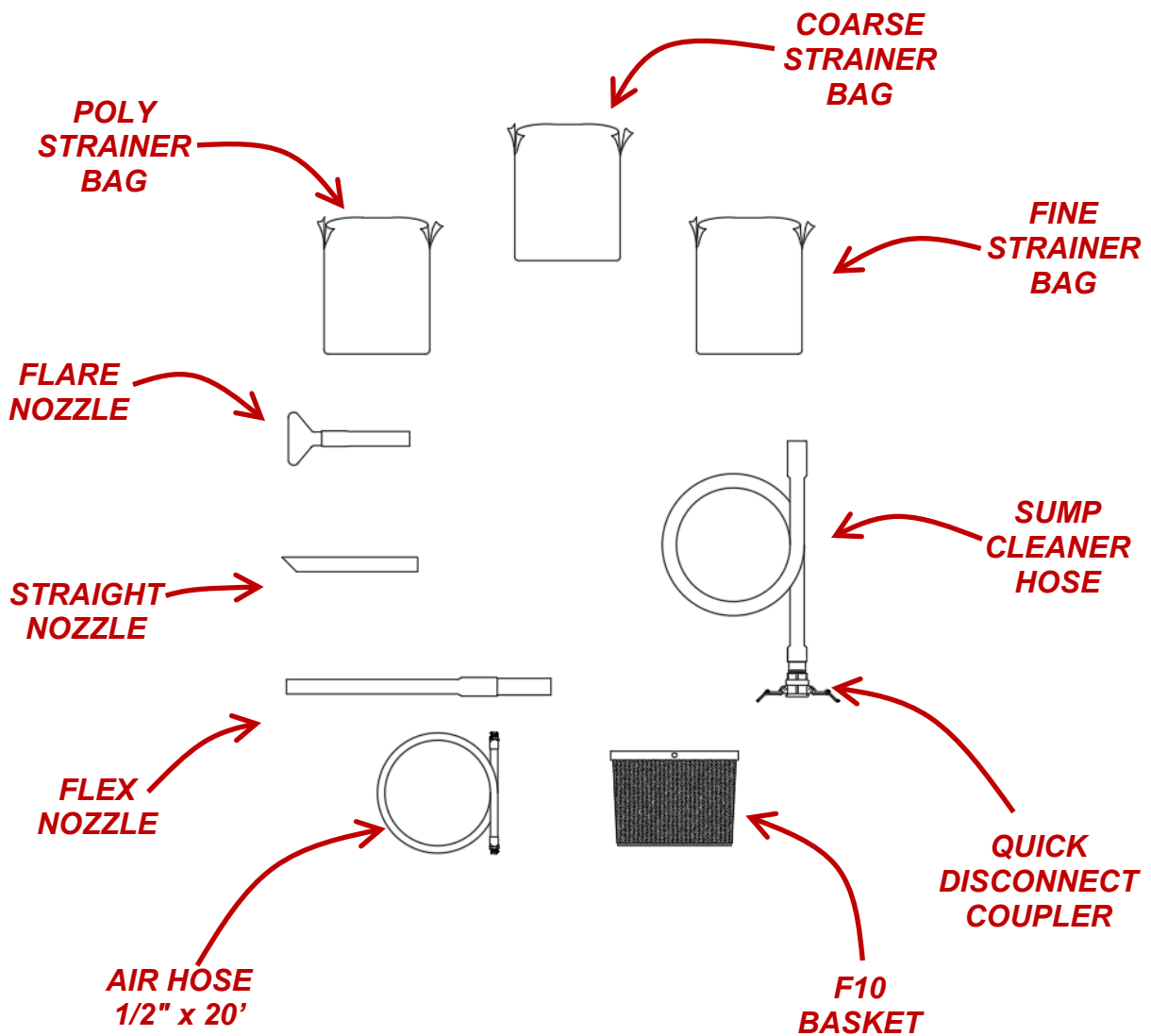

3.2 – INITIAL STARTUP

1. CLOSE AND SECURE ALL TANK SUCTION AND DISCHARGE PORTS.

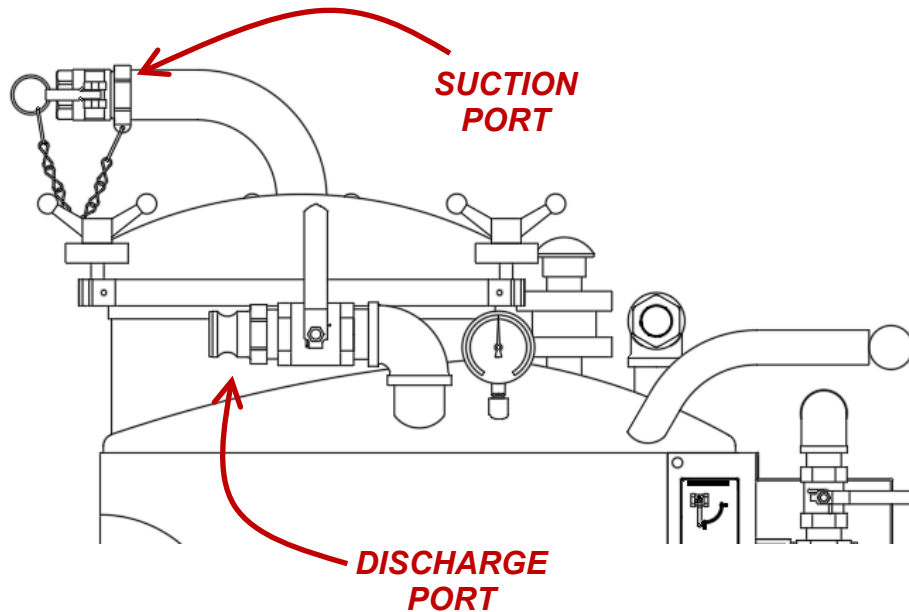

2. YOU ARE REQUIRED TO SUPPLY AIR CONNECTIONS THAT FIT YOUR AIR SYSTEM. THE SHARKS AIR-LINE TERMINATES IN 1/2" NPT PIPE THREAD. THE SHARK REQUIRES A MINIMUM 3/8" DISCONNECT; (1/2" FOR OPTIMAL PERFORMANCE). 1/4" BLOW-OFF CONNECTIONS ARE TOO LIMITING ON THE AIR SUPPLY REDUCING PERFORMANCE.

CECOR.
CECOR filter cartridges bear
US patent number 4,397,745

MODEL
SA5-60PL

SERIAL
SA5-###-###

70-120 PSI

VOLT H7 PH

1000 James Ave.
Belleville, WI 53508

608-845-6771 www.cecort.net

The label is a rectangular plate with rounded corners. A red circle is drawn around the "70-120 PSI" field. The "SERIAL" field contains a partially filled-in number "SA5-###-###".

3. **RUN THE UNIT IN “SUCTION” MODE.** WITH AIR SUPPLY VALVE IN THE OFF, POSITION CONNECT THE AIR-LINE TO YOUR SYSTEM. TURN SELECTOR VALVE TO SUCTION.

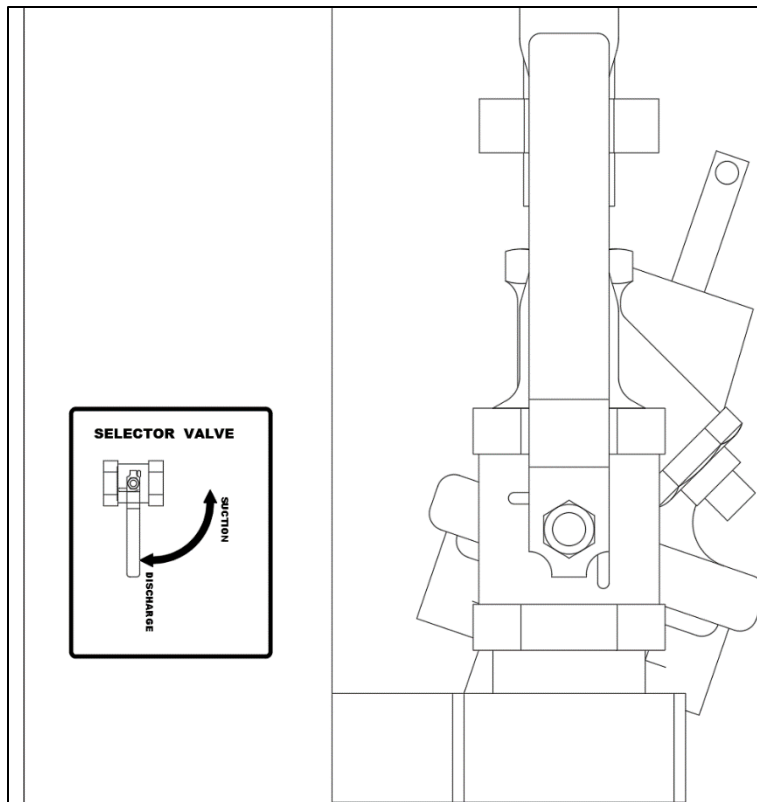
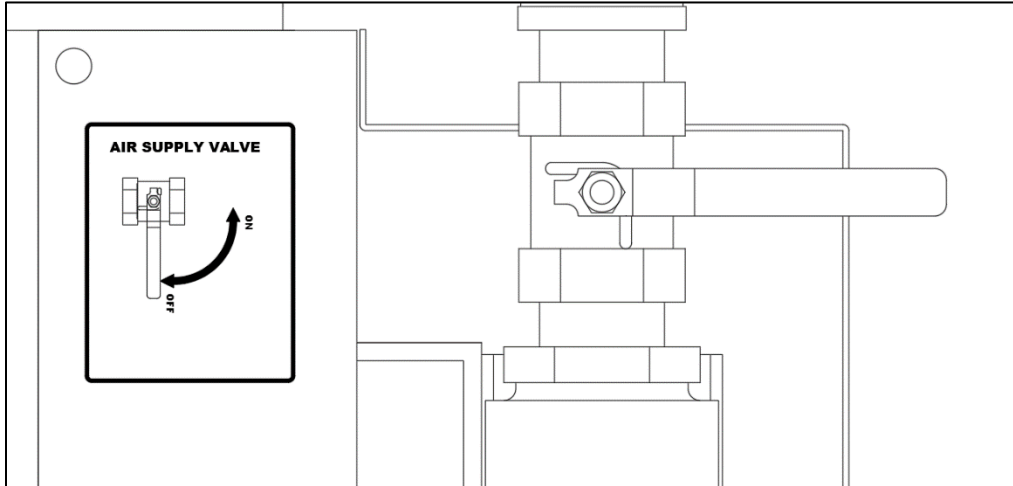

4. OPEN THE AIR SUPPLY VALVE. THE VACUUM READING SHOULD INCREASE TO 20-26" HG.

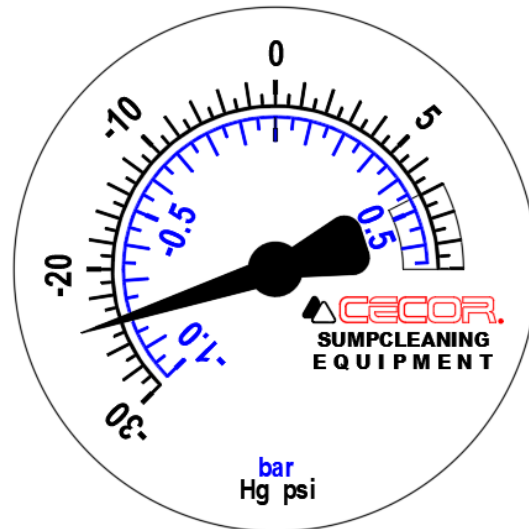

5. TURN SWITCH OFF. THE NEGATIVE PRESSURE IN THE TANK WILL CAUSE THE PUMP TO ROTATE BACKWARDS UNTIL THE PRESSURE EQUALIZES.
6. **RUN THE UNIT IN "DISCHARGE" MODE.** CHANGE THE PUMP-TO-TANK HOSE TO DISCHARGE CONNECTION.

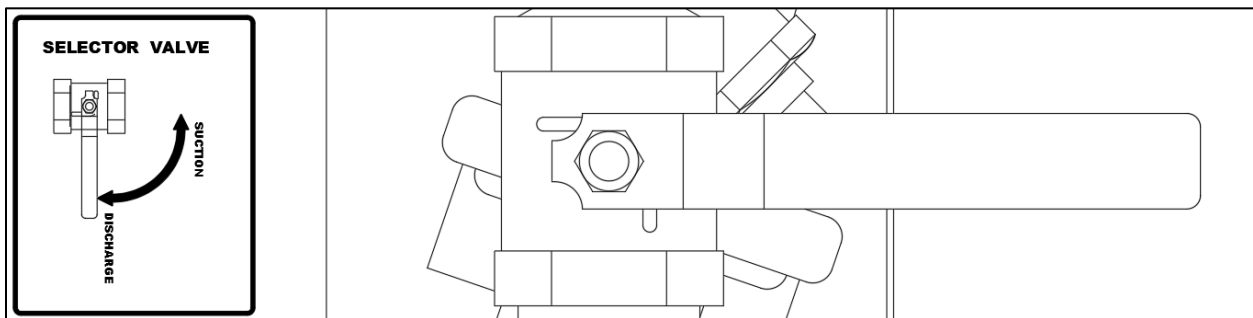

7. OPEN THE AIR SUPPLY VALVE. THE PRESSURE READING SHOULD INCREASE TO 5-7 PSI.

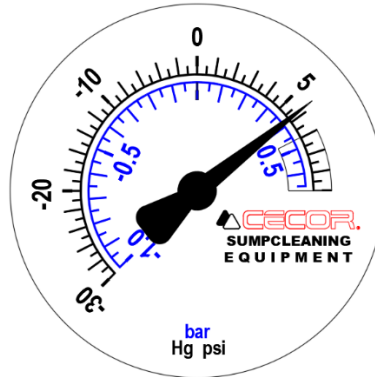

8. CLOSE AIR SUPPLY VALVE. TURN SELECTOR VALVE TO SUCTION. THE POSITIVE PRESSURE IN THE TANK WILL BE RELEASED THROUGH THE VACUUM SYSTEM. IF PRESSURE NEEDS TO BE RELIEVED FASTER RUN UNIT ON SUCTION MODE TILL GAUGE READS "0".
9. MACHINE IS READY TO USE.

SECTION 4 – OPERATION

4.1 – CLEANING A SUMP

1. ATTACH THE SUMP CLEANER HOSE TO THE SUCTION PORT, AND INSERT SUCTION TOOL INTO HOSE END.

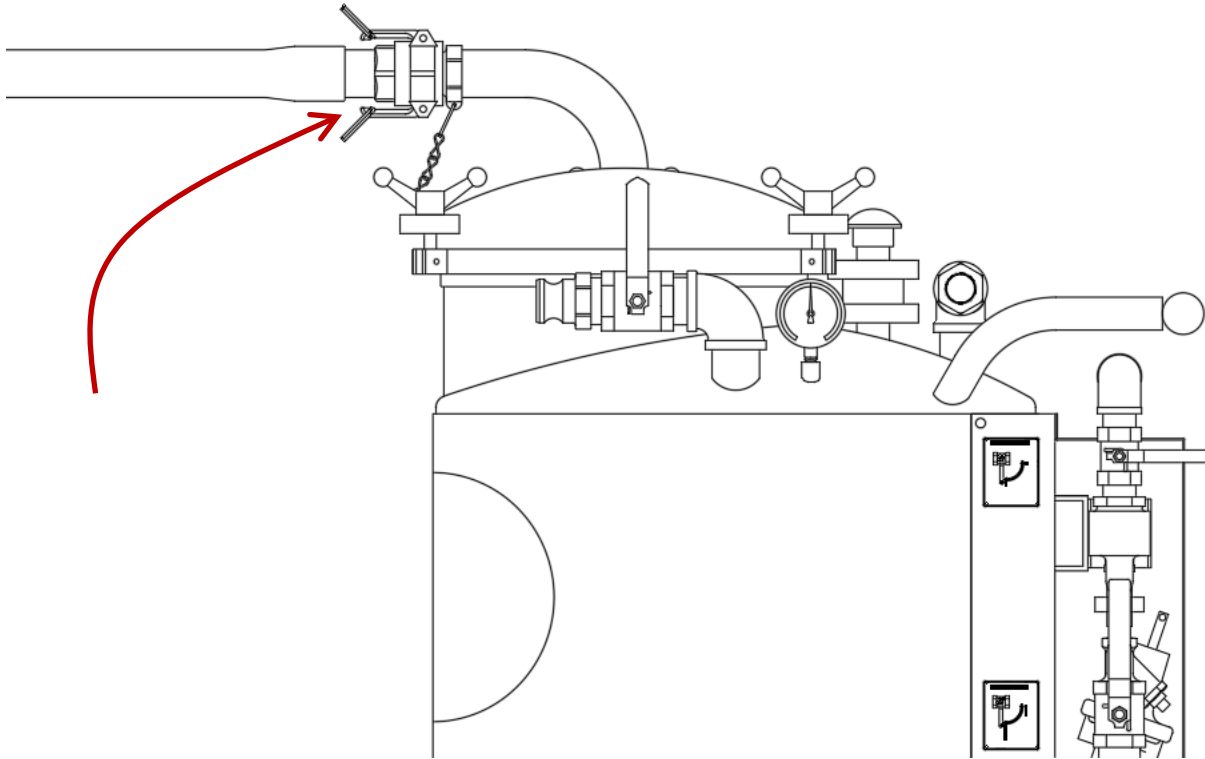

2. RUN UNIT ON SUCTION MODE. (SEE INITIAL STARTUP 3.2, STEP 3.)
3. WHEN VACUUMING OUT THE SUMP, ATTACK THE SOLIDS FIRST. POSITION THE SUCTION TOOL IN THE AREAS THAT ARE PRIMARILY SOLIDS. OCCASIONALLY MOVE THE SUCTION TOOL FROM THE SOLID PARTICULATE IN THE SUMP BOTTOM TO A PRIMARILY FLUIDIC AREA. THIS ACTION WILL CLEAR THE HOSE OF SOLIDS REDUCING THE CHANCES OF POSSIBLY PLUGGING THE HOSE.
4. WHEN THE TANK IS FULL, THE FLOAT CONTROL (LOCATED INSIDE THE SUMP CLEANER) WILL CUT OFF SUCTION TO THE PUMP ISOLATING THE PUMP FROM THE TANK (PUMP WILL KEEP RUNNING). WHEN THIS HAPPENS, THE VACUUM READING WILL FALL TO ZERO INDICATING THE TANK NEEDS TO BE EMPTIED.
5. WHEN THE FILTER IS FULL OR BLINDED, THE VACUUM/PRESSURE GAUGE WILL READ 10"++ HG, BUT THERE WILL BE NO SUCTION AT THE NOZZLE INDICATING THE FILTER NEEDS TO BE EMPTIED.

4.2 – DISCHARGING FLUID FROM THE SUMP CLEANER

1. ATTACH THE SUMP CLEANER HOSE TO THE DISCHARGE PORT, AND CAP THE SUCTION PORT.

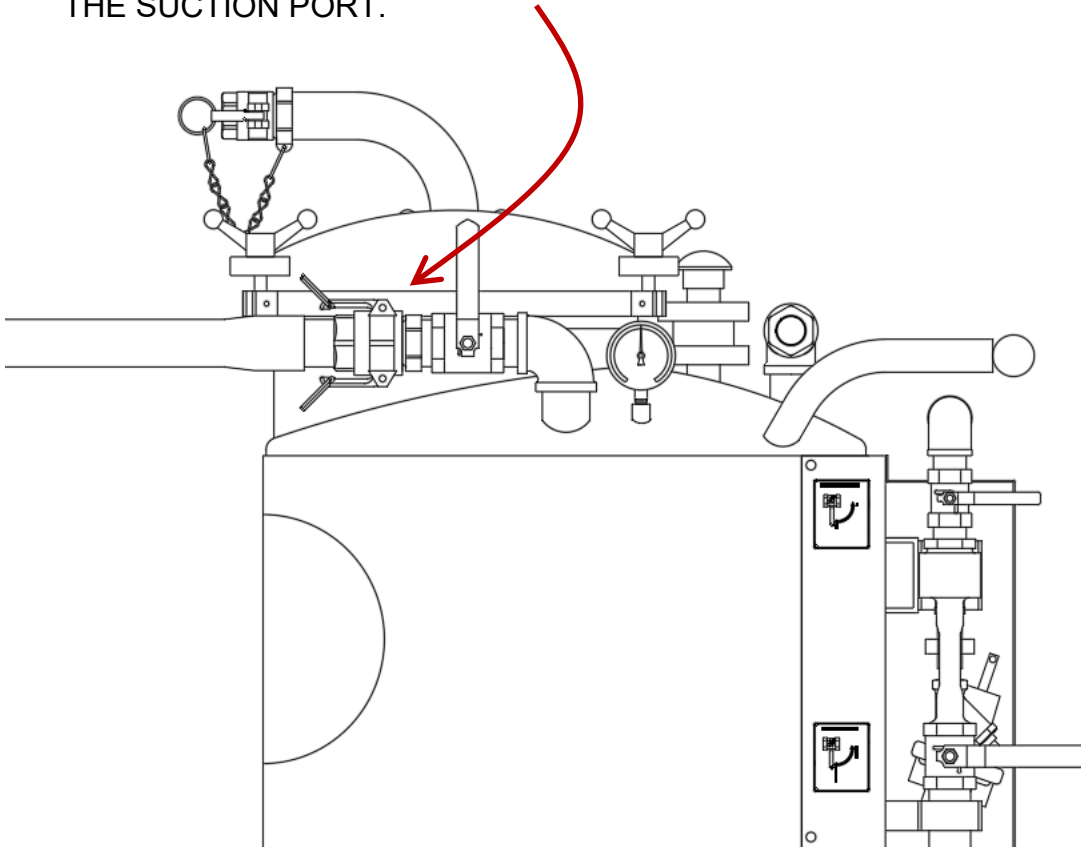

2. RUN UNIT ON DISCHARGE MODE. (SEE INITIAL STARTUP 3.2, STEP 6.)
3. POINT NOZZLE AT THE TARGET WHERE THE FLUID IS TO BE DISPENSED, SLOWLY OPEN DISCHARGE VALVE. SLUGS OF AIR WILL PASS THROUGH HOSE WHEN TANK APPROACHES EMPTY. THESE SLUGS CAN CAUSE ERRATIC FLUID FLOWS, BE PREPARED TO SHUT OFF DISCHARGE VALVE WHEN THIS OCCURS.

4.3 – FILTER

1. FILTERING OF THE FLUID IS SPECIFIC TO YOU. SUMP CONDITIONS VARY DUE TO ALL THE VARIABLES THAT OCCUR IN A MACHINE-TOOL SUMP. WE INCLUDE MULTIPLE FILTER BAGS SO YOU CAN FIND WHAT WORKS BEST FOR YOUR APPLICATION. FIRST-CLEANING CAN BE ESPECIALLY DIFFICULT IF IT HAS NOT BEEN DONE ON A REGULAR BASIS. WE SUGGEST STARTING WITH A COARSER BAG. ONCE ON A ROUTINE BASIS, A FINER FILTER CAN BE USED.
2. FILTERS ARE REUSABLE AND WASHABLE IN LUKEWARM WATER.

4.4 – CLEANING THE SUMP CLEANER

1. GENERALLY, DISCHARGING THE FLUID OUT OF THE SUMP CLEANER IS ALL THAT'S NEEDED. SOME SOLIDS WILL ACCUMULATE IN THE BOTTOM OF THE SUMP AND WILL REQUIRE A COMPLETE CLEANOUT OCCASIONALLY.
2. THE SA5 HAS A 2-1/2" DRAIN PLUG AND CAN EASILY BE ACCESSED BY LIFTING THE SUMP CLEANER AND REMOVING THE PLUG.

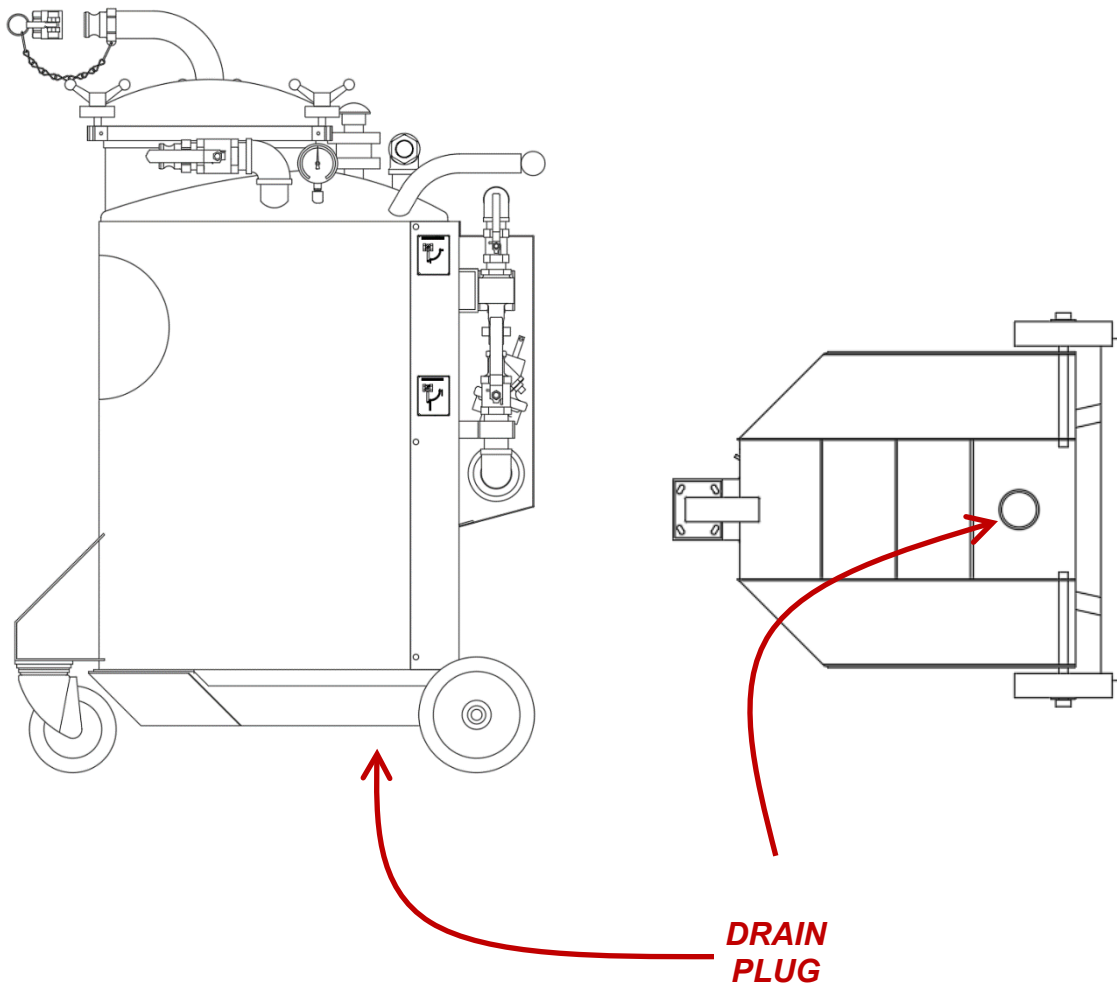

SECTION 5 – MAINTENANCE

TO GET THE HIGHEST PERFORMANCE FROM YOUR SUMP SHARK, IT IS IMPORTANT TO KEEP IT WELL MAINTAINED. BELOW IS A MAINTENANCE GUIDE THAT WILL KEEP YOUR SUMP CLEANER IN TOP-NOTCH, DEPENDABLE CONDITION. ANY WORN OR DAMAGED PART SHOULD BE REPLACED IMMEDIATELY. CECOR STOCKS SUMP CLEANER PARTS AND MOST CAN BE SHIPPED THE SAME OR THE NEXT DAY. CALL 1-800-356-9042 TO ORDER PARTS.

5.1 – DAILY MAINTENANCE

1. CHECK THE VACUUM/PRESSURE GAUGE TO SEE THAT IT IS OPERATING AND READING CORRECTLY. TANK PRESSURE SHOULD NOT EXCEED PRESSURES OF 7 PSI.
2. DEFECTIVE RELIEF VALVES SHOULD BE REPLACED IMMEDIATELY.
3. CHECK FOR GASKET LEAKS AND ANY TANK DAMAGE.

5.2 – WEEKLY MAINTENANCE

1. INSPECT TANK FOR SLUDGE BUILD UP. CLEAN TANK IF NECESSARY. WITH SOME APPLICATIONS, THE TANK MAY NEED TO BE CLEANED MORE FREQUENTLY. ALWAYS CLEAN THE TANK BETWEEN PUMPING DIFFERENT TYPES OF FLUIDS OR MATERIALS.
2. CLEAN AND INSPECT TANK FLOAT CONTROL. SEE THAT THE FLOAT BALL SEALS AGAINST THE GASKET. THE FLOAT CONTROL ASSEMBLY CAN BE ASSESSED THROUGH THE POT OPENING IN THE SUMP CLEANER.
3. CLEAN THE FILTER BAG BY RINSING IT OUT IN LUKEWARM WATER.
4. OPERATE PRESSURE RELIEF HANDLE TO MAKE SURE IT IS WORKING.

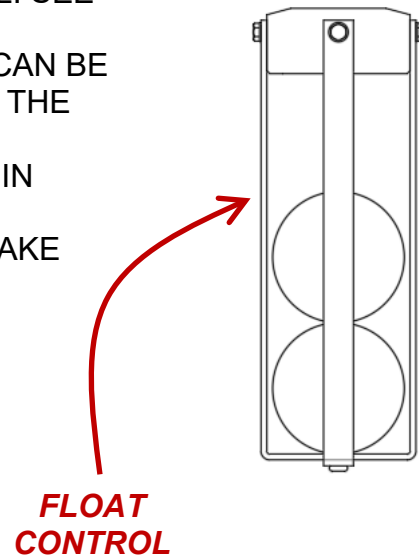

5.3 – MONTHLY MAINTENANCE

1. CHECK FOR WEAR ON POT LID WING NUTS AND STUDS.
2. INSPECT SUMP CLEANER HOSE.
3. GREASE THE SWIVEL CASTER AND WHEELS.

5.4 – SEMI ANNUAL

1. CLEAN AIR LINE STRAINER

SECTION 6 – TROUBLESHOOTING

PROBLEM	POSSIBLE CAUSES	CORRECTIVE ACTION
Will not start	Air Supply	Make sure the unit is connected to an adequate air supply.
	Hose Restrictions	Check air lines for kinks or other restrictions.
	Blockage of Air Flow	Check for debris that may have come through the air line.
Loss of suction	Vac/pres gauge reads full vacuum but has no suction.	Check filter. If full, empty. If blinded, clean or go to a coarser filter bag.
		Check hose for blockage.
		Check gauge; replace if needed.
	Vac/pres gauge reads "0" vacuum.	Tank is full; empty tank.
		Make sure discharge valve is closed.
		Air leakage; check gaskets and loose connections.
		Check tank selector valve and air supply
	Vac/pres gauge reads Low suction.	Check for correct size air connections.
		1/2 air-lines should not exceed 40'.
		Check for air flow out of the muffler.
Check tank selector valve and air supply for being completely open.		
Will not discharge	Vac/Pres gauge reads "6" psi.	Check discharge hose for blockage.
		Check for a build up of fines in tank bottom; clean if necessary.
	Vac/Pres gauge reads "0" psi.	Check that cap is on suction port.
		Air leakage; check gaskets and loose connections.
Fluid coming out of "Discharge" Tank-to - Pump connection.	Float Control	Check float control; clean or replace.
	Excessive Foaming	Consult coolant supplier.
	Tank Turbulence	Check to see if air is being sucked in the discharge.

SECTION 7 – REPAIR PARTS LIST

7.1 – WHEELS & CASTER

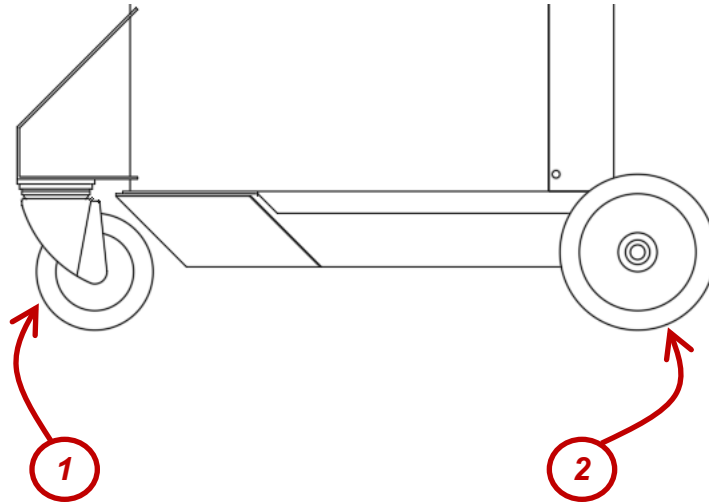

Ref	Part No.	Description
1	SP-289L	SWIVEL CASTER WITH PHENOLIC WHEEL LOCK
2	SP-329	WHEEL PHENOLIC

7.2 – TANK & PUMP

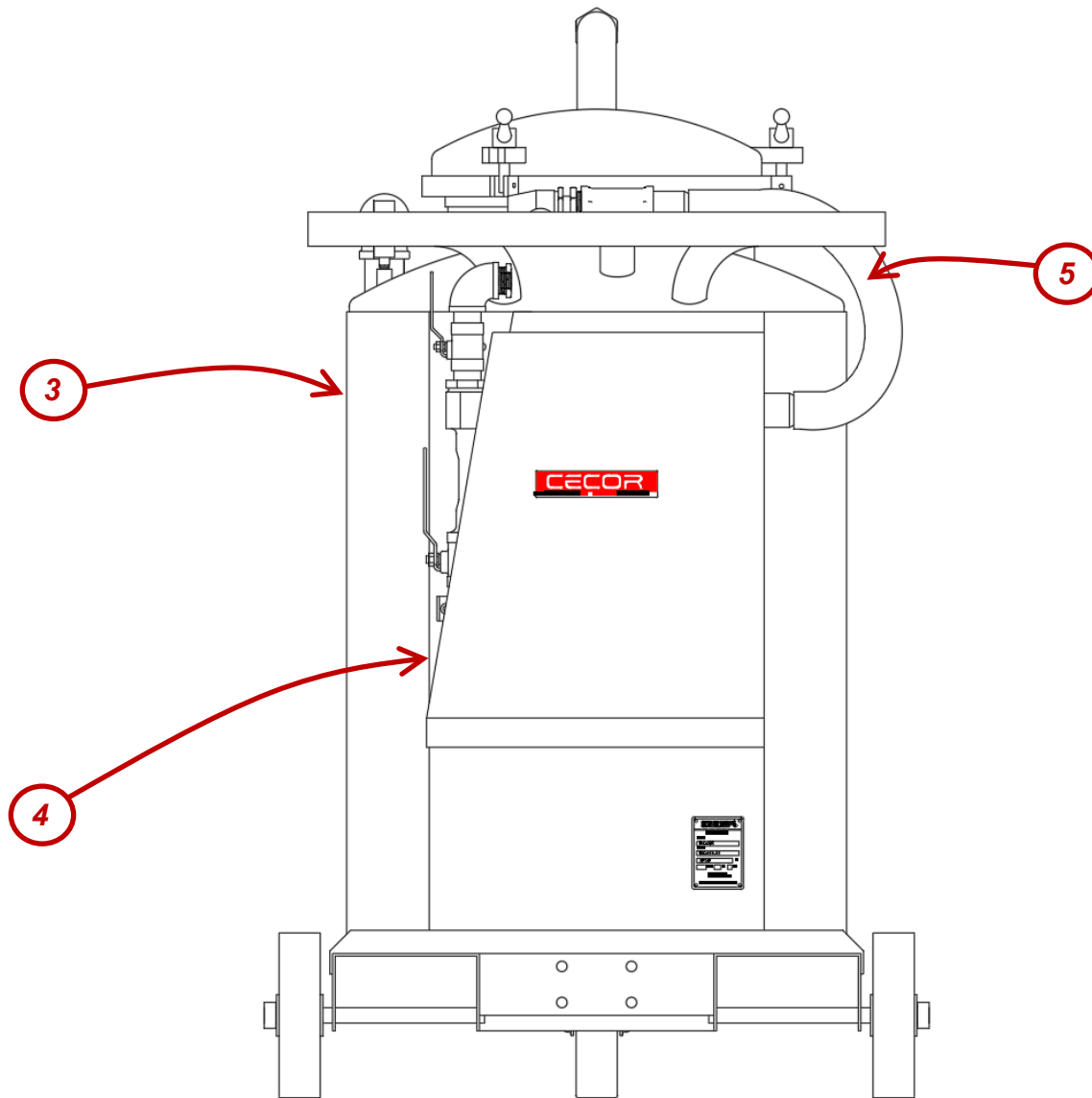

Ref	Part No.	Description
3	A220-647	TANK ASSEMBLY 60 GALLON
4	A220-746	VERTICAL PUMP ASSEMBLY AIR POWERED
5	A220-648	CONNECTING HOSE

7.3 – FILTER, TOOLS & HOSE

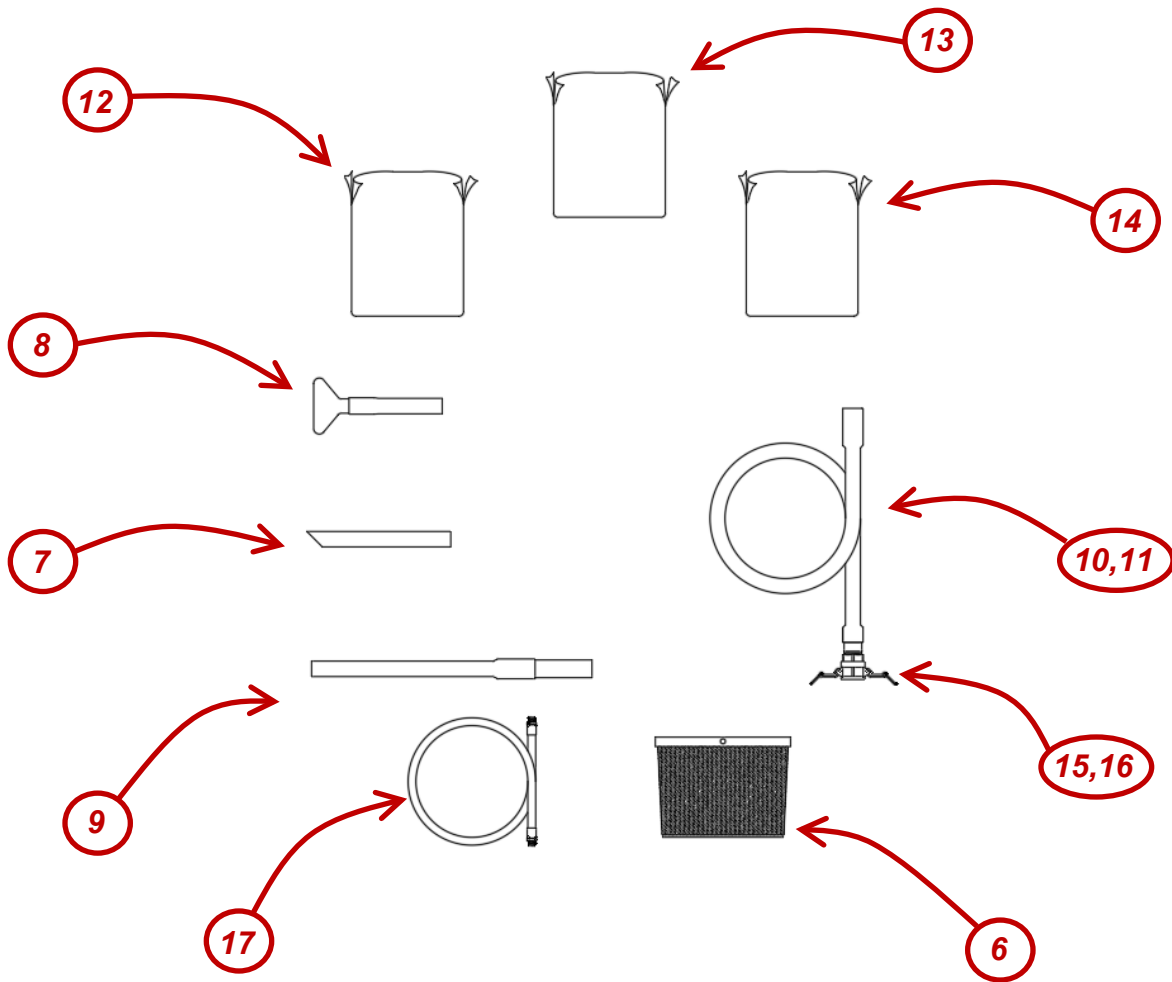

Ref	Part No.	Description
6	A210-431	F10 BASKET ASSEMBLY
7	A210-474	STRAIGHT NOZZLE
8	A220-149	FLARE NOZZLE
9	A220-150	FLEX NOZZLE
10	A220-142	SUMP CLEANER HOSE 16' CLEAR
11	A220-142R	SUMP CLEANER HOSE 16'
12	B210-530	POLY STRAINER BAG
13	A210-529C	COARSE STRAINER BAG
14	A210-529F	FINE STRAINER BAG
15	SP-404	QUICK DISCONNECT COUPLER
16	SP-370	COUPLER GASKET
17	SP-173	AIR HOSE 1/2" x 20'

7.4 – TANK CONNECTIONS, GAUGE, MOTOR & CONTROL SYSTEMS

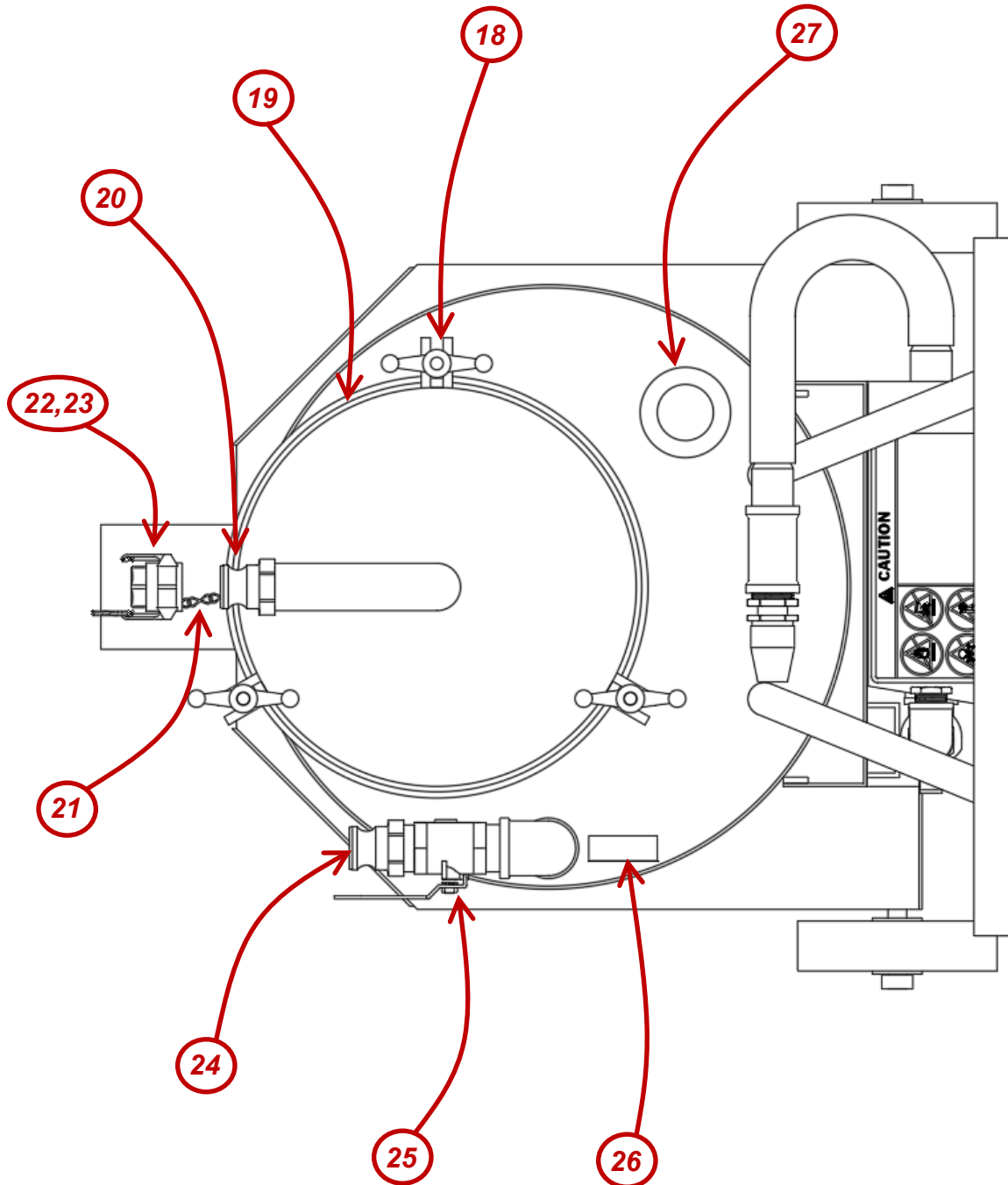

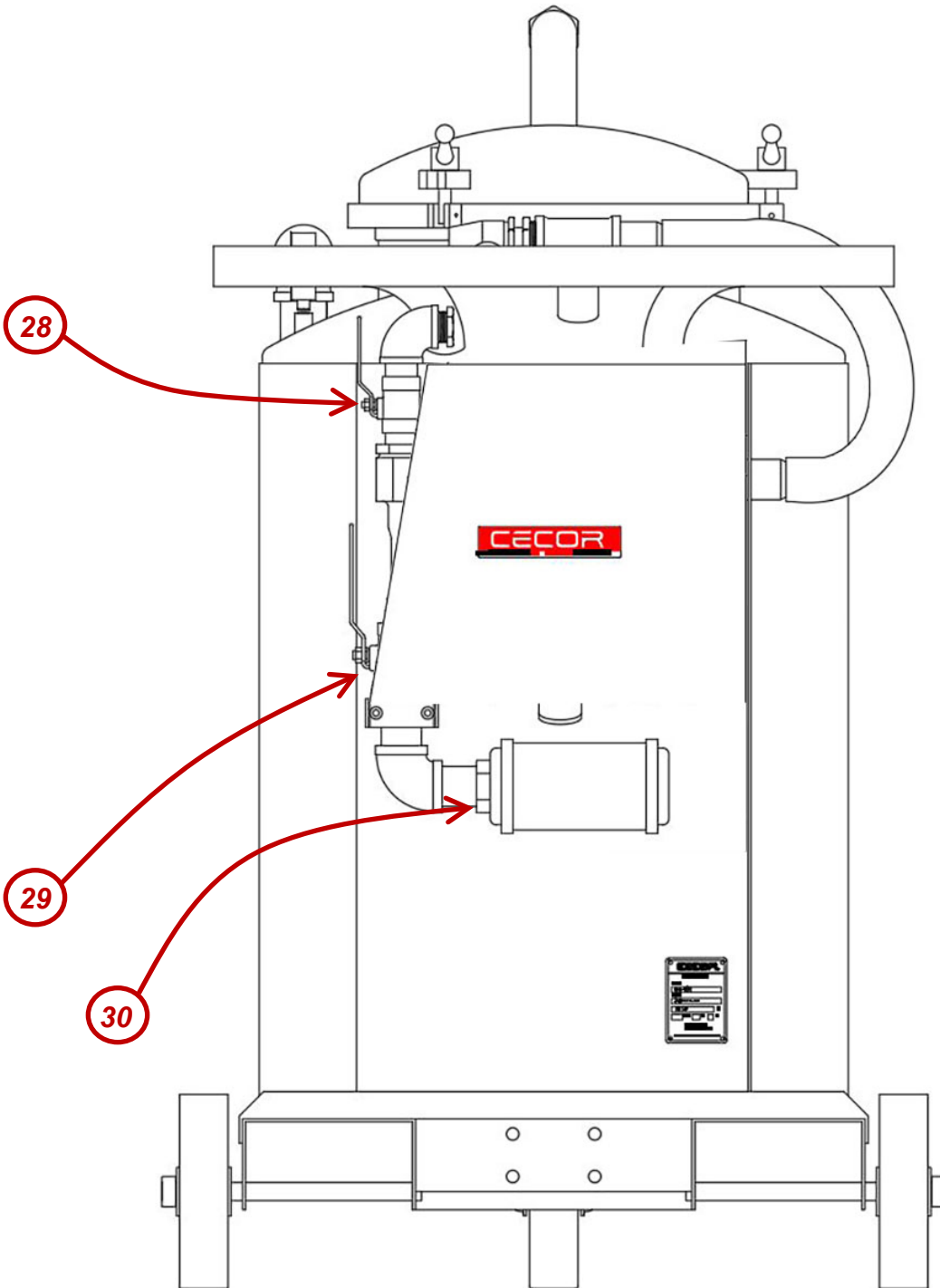

20	SP-405	QUICK DISCONNECT ADAPTER
21	SP-373	SECURITY CHAIN
22	SP-452	BLEED-OFF DISCONNECT CAP
23	SP-370	COUPLER GASKET
24	SP-368	QUICK DISCONNECT ADAPTER
25	SP-465	BUTTERFLY VALVE
26	SP-194	VACUUM / PRESSURE GAUGE
27	SP-382	RUPTURE DISC
28	SP-463	SELECTOR VALVE BUTTERFLY
29	SP-464	SELECTOR VALVE BUTTERFLY
30	SP-559	MUFFLER

SECTION 8 – WARRANTY

WARRANTY STATEMENT

PLEASE PRINT OUR WARRANTY AT [HTTPS://CECOR.NET/CECOR-WARRANTY/](https://cecor.net/cecor-warranty/)

SECTION 9 – RECORD MODEL & SERIAL NUMBER

WHEN YOU RECEIVE YOUR CECOR SUMP SHARK, RECORD THE MODEL NUMBER, SERIAL NUMBER AND DATE DELIVERED FOR YOUR RECORDS.

<p>MODEL #: _____</p> <p>SERIAL #: _____</p> <p>DELIVERED: _____ / _____ / _____</p>

CECOR®

